

MODEL NUMBER	IEEE100-36-405TS		
HORSEPOWER	100		
RPM / POLES	3600 / 2		
VOLTAGE / PHASE	460 / 3		
FRAME	405TS		
ENCLOSURE / DEGREE OF PROTECTION	TEFC / IP56		
FREQUENCY	60 HZ		
FULL LOAD SPEED	3570 RPM		
SERVICE FACTOR	1.15		
INSULATION CLASS	F Class N Varnish		
FULL LOAD AMPS; 460	110.1 A		
LOCKED ROTOR CURRENT (% Full Load)	700 %		
NEMA CODE LETTER	G		
EFFICIENCY / POWER FACTOR	<u>LOAD</u>	<u>EFF.</u>	<u>P.F.</u>
	100 %	94.5 %	90.5 %
	75 %	94.5 %	89.5 %
	50 %	92.4 %	87.5 %
DUTY CYCLE	S1 / Continuous		
TORQUE	<u>FULL LOAD</u>	<u>LRT</u>	<u>BDT</u>
	148.0 lb.ft	120 %	220 %
NEMA DESIGN	B		
MOMENT OF INERTIA	<u>LOAD (Max.)</u>	<u>MOTOR</u>	
	214.761 lb.ft ²	18.450 lb.ft ²	
SOUND PRESSURE LEVEL (No Load 1 M From Motor)	82 dB(A)		
MAX. SHAFT VIBRATION	0.08 In/Sec – Peak Velocity		
NUMBER OF STARTS (Hot / Cold)	2 Hot / 3 Cold		
MAX. AMBIENT TEMPERATURE	40° C		
MAX. ELEVATION	3300 Ft. Above Sea Level		
TEMPERATURE RISE (At Full Load)	80° C		
DRIVE-END BEARING	6313C3		
OPPOSITE DRIVE-END BEARING	6313C3		
BEARING SEAL TYPE	ProTech™ IP66 Labyrinth On DE and ODE		
GREASE TYPE	Mobil Polyrex EM		
MOUNTING	F1 (F2 Suitable), W6, W8, B3, V5, V6		
ROTATION	Uni-Directional, CCW		
APPROXIMATE WEIGHT	1110 lbs		
AREA CLASSIFICATION	Class I, Division 2, Groups A, B, C, D, T3A		
PAINT	Epoxy		
INVERTER RATING	10:1 CT / 1000:1 VT		
INSULATION TYPE	Hyundai Inverter Shield, Meets NEMA MG1 Part 31		
SPECIFICATION - In Accordance With	IEEE-841, Version 2009, NEMA, CSA		



CC 038A



본 도면은 현대중공업(주) 재산이며 복제할 수 없습니다 (취급유의)

THIS DRAWING IS PROPRIETARY TO HEECO. NO PART OF THIS DRAWING MAYBE REPRODUCED WITHOUT THE PERMISSION OF HHI.

		<h1>IEEE841 TEFC</h1> <h2>THREE PHASE INDUCTION MOTOR</h2>		TYPE PLP Cast iron frame
FRAME SIZE	OUTPUT(HP)	POLES	Hz	TIME RATING
405TS			60	CONT

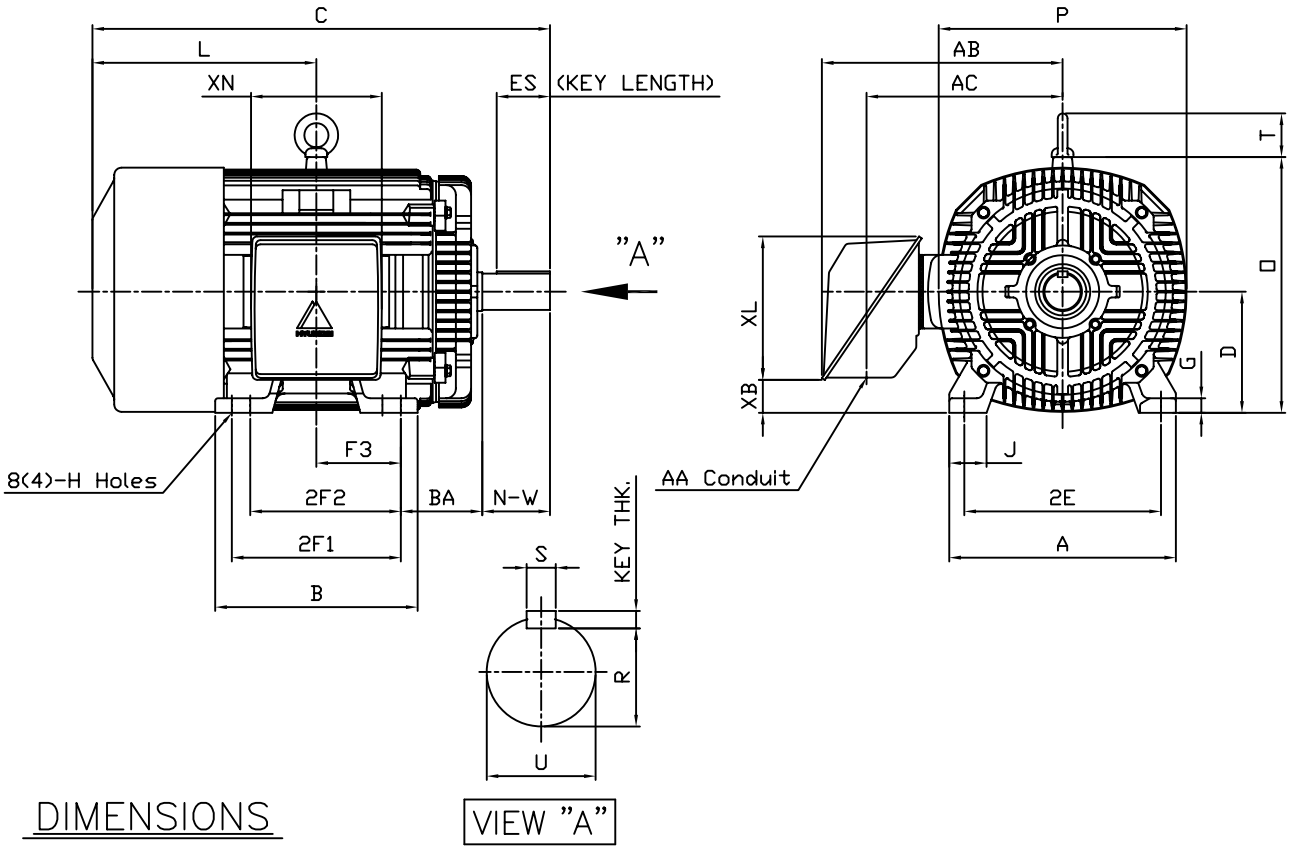

DIMENSIONS

VIEW "A"

M O U N T I N G									C O N D U I T B O X					APPROX. WGT.(LB)	
A	B	2E	2F1	2F2	F3	G	J	H	AA	AB	AC	XB	XL		XN
18.43	16.46	16.00	13.75	(12.25)	6.870	1.18	3.03	0.81	3.00	20.28	14.85	2.83	11.65	10.63	1110

O V E R A L L							S H A F T			KEY	BEARING			
BA	C	D	L	O	P	T	U	N-W	KEYWAY			THK.	DRIVE END	OPP. DRIVE END
									R	ES	S			
6.62	38.00	10.00	20.57	20.79	20.16	3.55	2.125	4.25	1.845	2.80	0.500	0.500	6313C3	6313C3

NOTE

1. Dimension "D" tolerance : +0.00inch - 0.03inch (143T-365T) ; +0.000inch - 0.06inch (404T-449T)
2. Dimension "U" tolerance : +0.000inch - 0.005inch (143T-215T), +0.000inch - 0.001inch (254T-449T)
3. Dimension "R" tolerance : +0.000inch - 0.015inch

Q'TY	DESCRIPTION	MATERIAL	DIMENSION	WEIGHT	PART NO.	REMARK	NO.
APPD BY	K.J.KANG	UNIT	INCH	SUBJECT	405TS	CAD PROJ ㄹ \ FILE ㄹ MMSTDMTR\A8116BA	
Q.P CHK	O.J.KIM	SCALE	N/S				
CHKD BY	N.D.LEE	PROJEC'N	3 각법(3rd Angle)	TITLE <h1>OUTLINE</h1>			
DSND BY	A.L.SHIN	DATE	2011.03.31				
				REF. NO	A8116BA	Sheet No.	of
				DWG NO	350A8116BA	Revision No.	0



PERFORMANCE CURVE

CURVE NO.

P-PLP405SR02

Type	: PLP
Full Load Torque	: 148.0 lb.ft
Motor moment of Inertia (J)	: 18.450 lb.ft ²
Load moment of Inertia (J)	: 214.761 lb.ft ²

75 kW	100 HP	60 Hz	
2 P	Rated Speed	: 3570 RPM	
Rated Voltage	575V	460V	230V
Full Load Current	88.1A	110.1A	220.1A

SPEED VS TORQUE & CURRENT CURVE

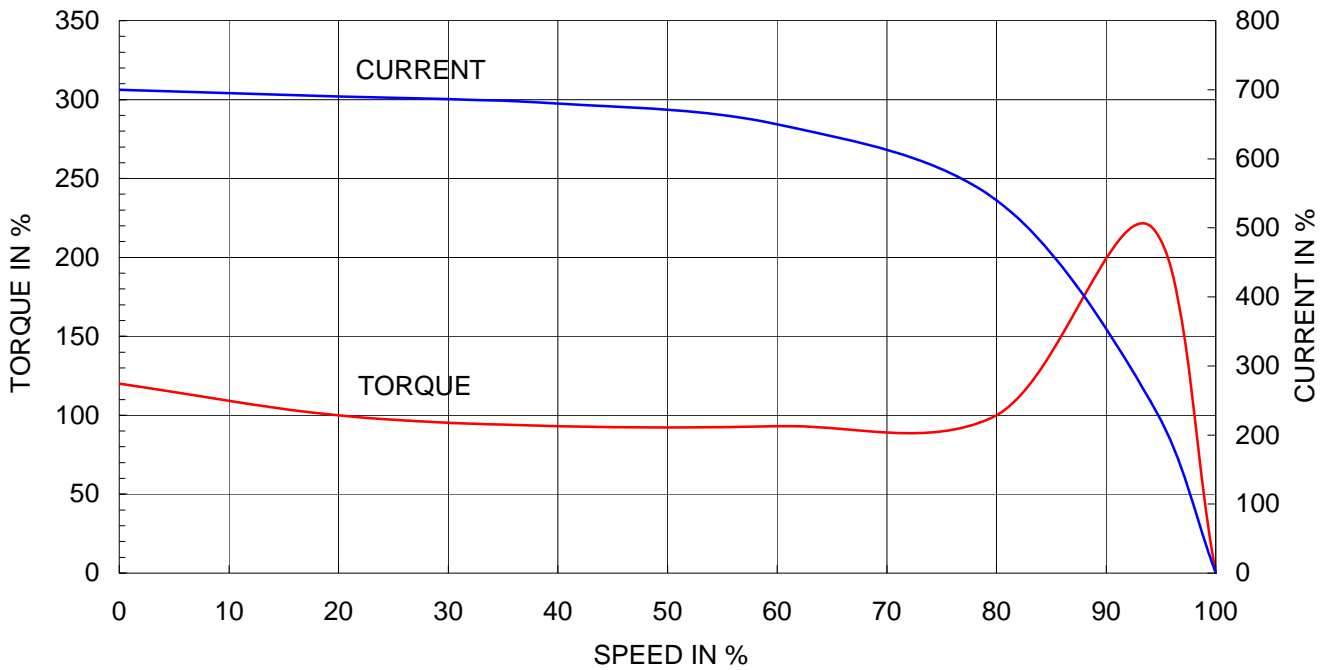

OUTPUT VS EFF., P.F & CURRENT CURVE

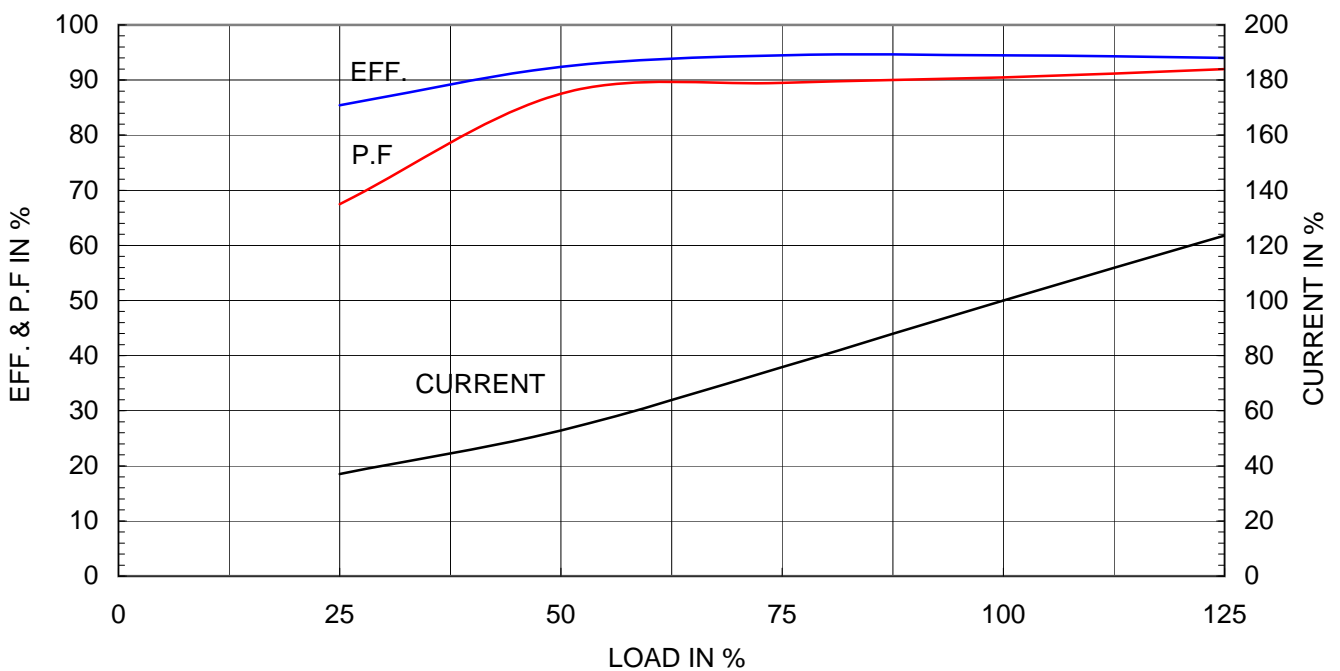



THERMAL LIMIT & TIME CURRENT CURVE

CURVE NO.

T-PLP100-36-405TS

Type :	PLP100-36-405TS		100	HP	2	P	60	Hz
FULL LOAD TORQUE :	148.0	lb.ft	RATED SPEED :		3570 rpm			
J OF LOAD :	-	lb.ft ²	VOLTAGE		460 V	575 V		
J OF MOTOR :	18.4	lb.ft ²	RATED CURRENT		110.1A	88.1A		

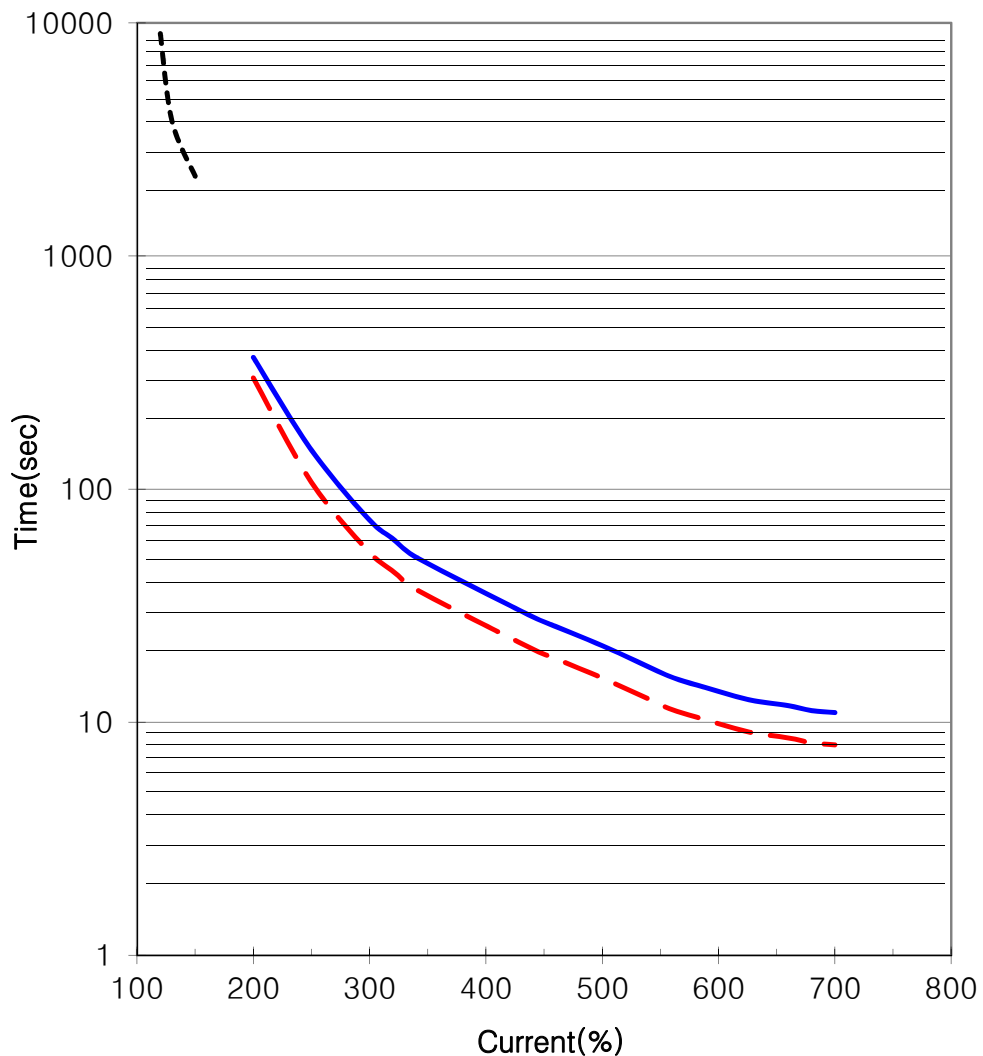

— THERMAL LIMIT CURVE AT COLD CONDITION
- - THERMAL LIMIT CURVE AT HOT CONDITION

STARTING TIME	SAFE STALL TIME
- at rated voltage starting	8 sec. at Hot condition
- at 80% of rated voltage starting	11 sec. at Cold condition

THIS DRAWING IS PROPRIETARY TO HHI. NO PART OF THIS DRAWING MAY BE REPRODUCED WITHOUT THE PERMISSION OF HHI.

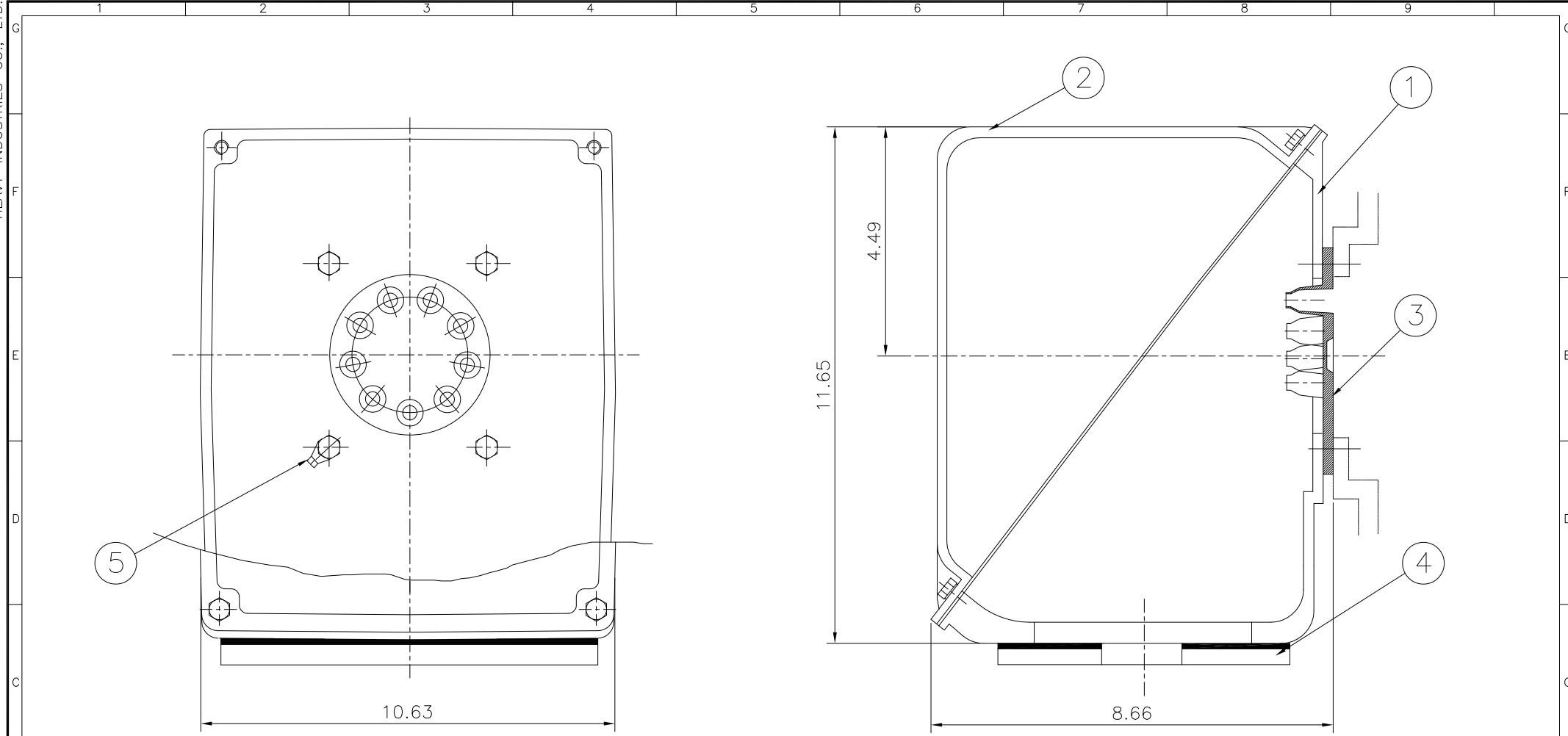

▽	50S
▽▽	12.5S
▽▽▽	3.2S
▽▽▽▽	0.4S

REV	DATE	CONTENTS	REVD BY	CHKD BY	CHKD BY	APPD BY
1						

일반기능공차		일반제관공차	
1-4	±0.1	6-30	±0.5
4-18	±0.2	30-120	±0.8
18-63	±0.3	120-315	±1.2
63-250	±0.5	315-1000	±2.0
250-	±0.8	1000-	±3.0

1	EARTH TERMINAL LUG						5
1	CABLE ENTRY PLATE						4
1	GASKET	NBR					3
1	TERMINAL BOX COVER	CAST IRON					2
1	TERMINAL BOX BODY	CAST IRON					1
Q'TY	DESCRIPTION	MATERIAL	DIMENSION	WEIGHT	PART NO.	REMARK	NO.
APPD BY	KANG KYEONG JUNG	UNIT	INCH	SUBJECT	NEMA 400, 440		DWG SIZE
CHKD BY	KIM JIN HONG	SCALE	Non Scale				A3 (1:1)
CHKD BY	KIM OK JIN	PROJEC'N	3각법 (3rd Angle)	TITLE			
DSND BY	KIM RYANG GYU	DATE	2011-10-21	Main Terminal Box Assembly			
REF. NO		Sheet No.	of				
DWG NO	3M-016882	Revision No.	0				